



NTI NETWORK 1275 Danner Dr Tel:330-562-7070
TECHNOLOGIES Aurora, OH 44202 Fax:330-562-1999
INCORPORATED www.networktechinc.com

VEEMUX[®] Series

SM-nXm-C5AV-LCD

Audio/Video Matrix Switch via CAT5
Installation and Operation Manual
Software Version 1.14



Used with NTI ST-C5VA-600 (XTENDEX™) (NOT INCLUDED)

TRADEMARK

VEEMUX is a registered trademark of Network Technologies Inc in the U.S. and other countries

COPYRIGHT

Copyright © 2003-2007 by Network Technologies Inc. All rights reserved. No part of this publication may be reproduced, stored in a retrieval system, or transmitted, in any form or by any means, electronic, mechanical, photocopying, recording, or otherwise, without the prior written consent of Network Technologies Inc, 1275 Danner Drive, Aurora, Ohio 44202.

CHANGES

The material in this guide is for information only and is subject to change without notice. Network Technologies Inc reserves the right to make changes in the product design without reservation and without notification to its users.

Note: Shielded CAT 5,5e, or 6 cable must be used to connect to LOCAL and REMOTE units in order to meet CE emission requirements.

TABLE OF CONTENTS

INTRODUCTION	1
Materials	1
Default User Name and Passwords	2
FEATURES AND FUNCTIONS.....	2
VEEMUX Features and Functions.....	2
XTENDEX Features and Functions.....	3
XTENDEX INSTALLATION.....	4
Audio Compatibility.....	4
The Local Unit.....	4
The Remote Unit.....	6
Plug-in and Boot Up.....	7
VEEMUX INSTALLATION.....	8
USING THE VEEMUX SWITCH	10
Front Panel Interface Overview	10
Keypad Control	11
Configuration Menu.....	11
Set Serial Address	12
Set Serial Speed	12
Set IP Address	12
Set Subnet Mask.....	12
Set Default Gateway.....	12
Set Wserver Timeout	13
Adjust Contrast	13
Video Adjustment.....	13
Show Size	13
Displaying Audio Level (Digital VU-Meter)	13
RS232 Interface.....	14
Matrix Switcher's Control Program For Windows 9X, NT, 2000 and XP	15
Telnet Interface-Port 2000	16
Telnet Interface-Port 2005	17
Command Summary	17
Command Detail	17
RU-Read Unit Size	17
RO-Read Connection for Output Port	17
CS- Connect Output Port to Input Port.....	18
CA- Connect All Output Ports to Input Port.....	18
SS_00- Enable Auto Status Mode.....	18
SS_01- Disable Auto Status Mode.....	19
SX- Examine connections	19
Terminate telnet session	19
Web Interface	20
Enter the Password	20
Switch Page.....	21
Setup Pages	23
Video Input Names	24
Video Output Names	24
Outputs Scanning Sequences	25
Update Firmware	26
Change Password Page.....	27
Help Page.....	27
Update Web Server	27
Logout Page	28
DEVICE DISCOVERY TOOL.....	29
INTERCONNECTION CABLE WIRING METHOD	30
CAT5 Cable	30
Serial Cables	30

TROUBLESHOOTING	31
APPENDIX	32
INDEX.....	34
WARRANTY INFORMATION.....	34

TABLE OF FIGURES

Figure 1- Connect the Local Unit to the CPU.....	4
Figure 2- Connect Local User Components to Local Unit.....	5
Figure 3- Connect the Extended Components to the Remote Unit.....	6
Figure 4- Connect the AC adapters	7
Figure 5- Attach ST-C5VA-600 Local Unit to VEEMUX.....	8
Figure 6- Attach ST-C5VA-600 Remote Unit to VEEMUX.....	8
Figure 7- Maximum total CAT5 cable length cannot exceed 600 feet.....	9
Figure 8- Connect VEEMUX to LAN.....	9
Figure 9- Connect user terminal to VEEMUX	9
Figure 10- Front panel Interface LCD and keypad.....	10
Figure 11- VEEMUX start-up message on LCD.....	10
Figure 12- Connections screen on LCD, displays 8 sets at a time.....	10
Figure 13- Configuration menu on LCD	11
Figure 14- Set Serial Address from LCD and keypad.....	12
Figure 15- Set baud rate from LCD and keypad	12
Figure 16- Set IP Address from LCD and keypad.....	12
Figure 17- Wserver Timeout Period.....	13
Figure 18- Adjust LCD contrast.....	13
Figure 19- View Output audio level.....	13
Figure 20- Web interface Welcome page.....	20
Figure 21- Web interface Login Prompt	20
Figure 22- Web interface Switch page	21
Figure 23- Web interface Setup page	23
Figure 24- Web interface Serial Setup page.....	23
Figure 25- Web interface Video Input Names page	24
Figure 26- Web interface Video Output Names page	24
Figure 27- Outputs Scanning Sequences page	25
Figure 28- Web interface Update Firmware page.....	26
Figure 29- Web interface Password page.....	27
Figure 30- Updating the Web Server	27
Figure 31- Web interface Logout page.....	28
Figure 32- Device Discovery Tool page.....	29
Figure 33- View looking into RJ45 female.....	30
Figure 34- Mount Switch to a Rack.....	33

APPENDICES

Appendix A- Default Settings	32
Appendix B- General Information.....	32
Appendix C- Distances and Resolutions for CAT5/CAT5e and CAT6 Cables.....	32
Appendix D- Product Dimensions	32
Appendix E- Rack mounting Instructions	33

INTRODUCTION

The SM-nXm-C5AV-LCD (VEEMUX) is an Audio/Video Matrix switch via CAT5 designed to work in conjunction with the NTI ST-C5VA-600 or ST-C5SVA-600 CAT5 Audio/Video Extender (XTENDEX). Up to 32 audio/video sources can be connected to the VEEMUX via XTENDEX Local Units (n), each accessible by up to 16 audio/video displays connected via XTENDEX Remote Units (m).

The VEEMUX enables connections from any single XTENDEX Local Unit to any or all of the connected XTENDEX Remote Units, creating a matrix of possible CAT5 audio/video connections. Audio/video displays can be located up to 600 feet away from the connected source.

The available models are:

SM-8X8-C5AV-LCD	SM-16X8-C5AV-LCD	SM-32X8-C5AV-LCD
SM-8X16-C5AV-LCD	SM-16X16-C5AV-LCD	SM-32X16-C5AV-LCD

Features

- Up to 16 audio/video displays may be connected to up to 32 audio/video sources (via ST-C5VA-600 Extenders)
- Multiple methods of user setup and control:
 - Front Panel Interface with LCD and keypad
 - Web Interface with multiple pages with secure socket layer (SSL) encryption to provide secure access between the client browser and central server. Supports SSLV3/TLSV1 protocol.
 - Telnet Interface
 - RS232 Interface
- Digital VU-Meter that displays the stereo audio levels for the currently selected port (displayed by LCD).
- Automatic video quality adjustment, with additional manual control, assures maximum video quality at lengths of up to 600 feet.
- All connections between local sources and remote displays can be made using CAT5, CAT5e, or CAT6 UTP cable.
- Ethernet connection speed is 10/100baseT
- A monitor can only be connected to one audio/video source at a time.

Supported Web Browsers:

Most modern web browsers should be supported. The following browsers have been tested:

- Microsoft Internet Explorer 6.0 or higher
- Netscape 7.0 or higher
- Mozilla FireFox 0.9.2 or higher

Set your browser to always check if there is a newer version of the page than the version stored in cache. This action will ensure that it will display the most up-to-date information.

Materials

Materials Supplied with this kit:

- NTI SM-nXm-C5AV LCD Audio/Video Matrix switch via CAT5
- IEC Line cord, country specific
- 4-#10-32 x 3/4" pan head screws and 10-32 cagenuts (server cabinet mounting hardware)
- CD with: a pdf file of this owner's manual
the NTI Discovery Tool
the Matrix Switcher's Control Program

Materials *Not* Supplied, but **REQUIRED**:

- XTENDEX Local and Remote Units with either CAT5 Unshielded Twisted Pair (UTP) cable, CAT5e cable, or CAT6 cable. Cable(s) must be terminated with appropriate RJ45 connectors wired straight thru- pin 1 to pin 1, etc. (see pg. 30 for proper EIA/TIA 568 B wiring method)
- A serial cable with DB9 connectors on each end wired straight through (pin 1 to pin 1, pin 2 to pin 2, etc.) will be required for RS232 connection to a remote terminal. See page 30 for cable pinouts.

Cables can be purchased from Network Technologies Inc by calling 800-RGB-TECH (800-742-8324) or (330)-562-7070 or visit our website at www.networktechinc.com.

Default User Name and Passwords

The default Telnet password is **admin** (lower case letters only) . For instruction on using Telnet, see page 16.

The default Web Interface user name is **Administrator** (upper case letter for "A" only).

The default Web Interface password is **admin** (lower case letters only). For instruction on using the Web Interface, see page 20.

FEATURES AND FUNCTIONS

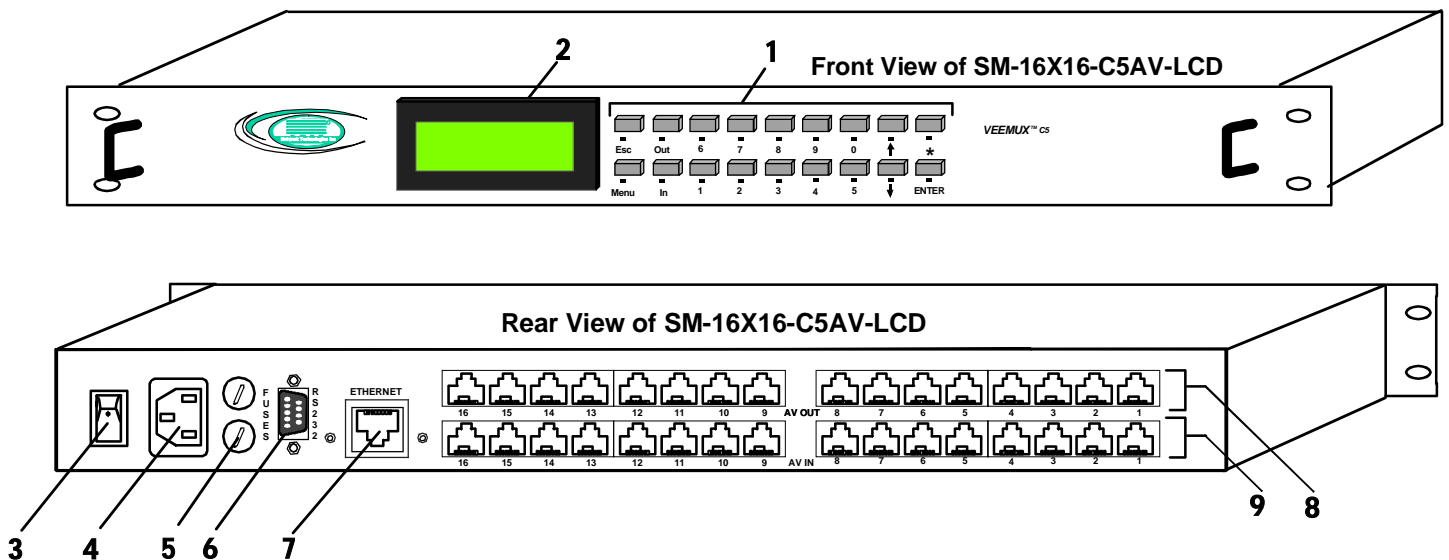

VEEMUX Features and Functions

1. **Keypad**- for manual user control of connections and switch programming
2. **LCD**- for visual indication of connections and audio level indication
3. **Power switch**- used to power the VEEMUX On/Off
4. **IEC Power Connector**- for attachment of power cord
5. **Fuseholder**- for replaceable 2A 250V overcurrent protection fuse (fuses mounted inside case on some models)
6. **RS232**- DB9 female- for connecting a serial cable for a user terminal
7. **Ethernet**- RJ45 female- for connecting the VEEMUX to a network.
8. **AV OUT**- RJ45 female- for connection of CAT5 cables from CAT5 Extender Remote Units
9. **AV IN**- RJ45 female- for connection of CAT5 cables from CAT5 Extender Local Units

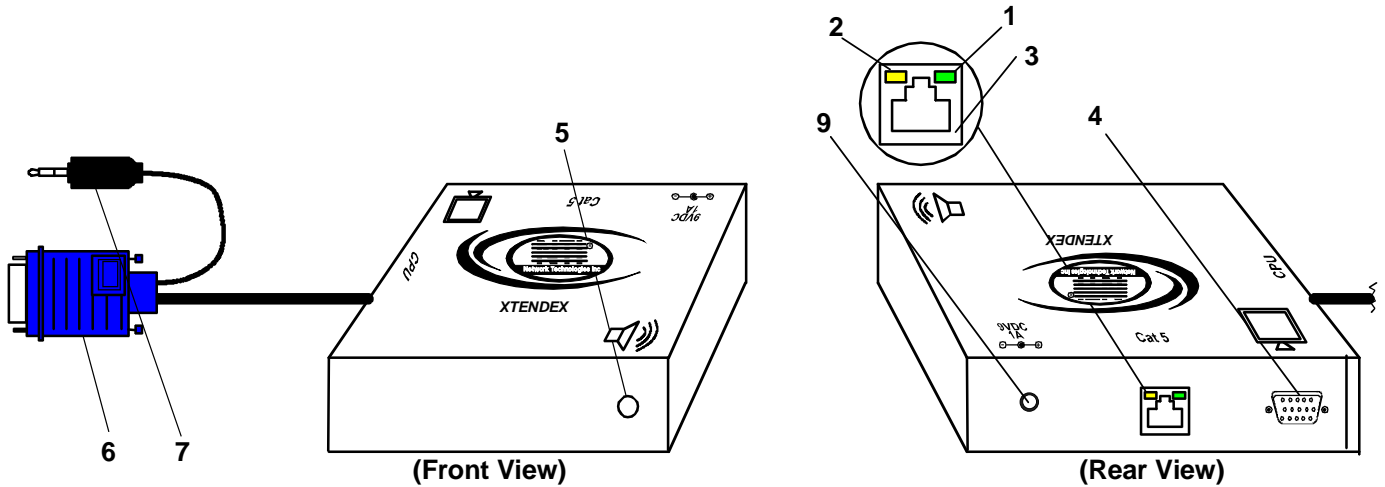

ST-C5VA-600 Local Unit (VGA plus Audio)
(not included)

XTENDEX Features and Functions

1. **Green LED**- power indicator- illuminates when power has been supplied to the unit
2. **Yellow LED**- communication indicator- blinks when there is valid communication between the local and remote units
3. **Cat 5**- RJ45 female- for connecting the CAT 5 cable
4. **Video Connector**- 15HD female- for connecting the local user's monitor
5. **Audio Jack**- 3.5mm stereo audio jack- for connecting to local speakers
6. **Video Connector**- blue 15HD male- for connecting to the video port on the CPU or KVM switch
7. **Audio Plug**- 3.5mm stereo audio plug- for connecting to CPU audio line out
8. **Audio Jack**- 3.5mm stereo audio jack- for connecting to remote speakers
9. **9VDC- 1.0A**- connection jack for the AC adapter
10. **Video Connector**- 15HD female- for connecting the remote user's monitor
11. **AC Adapter**- to power the Remote and Local Units (1 for each required)

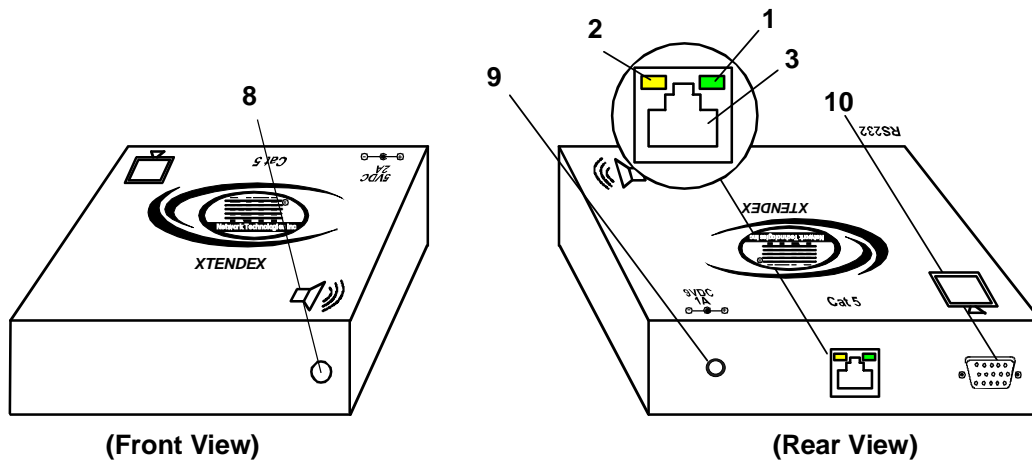
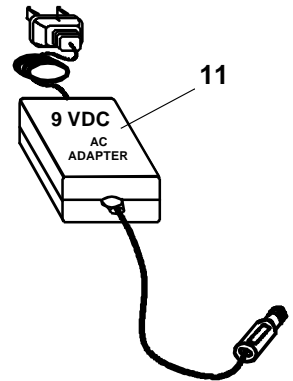

ST-C5VA-600 Remote Unit (VGA plus Audio)
(not included)

XTENDEX INSTALLATION

(XTENDEX not included)

Audio Compatibility

- The audio input of the ST-C5VA-600 Audio/Video Extender is compatible with the following standard CPU audio outputs:
 - Line out - typically lime green in color
 - Speaker out- typically orange in color
 - Headphone out- typically located on the CD-ROM (audio extension cable would be needed)
- The audio output of the ST-C5VA-600 Audio/Video Extender is compatible with self-powered stereo speakers.

The Local Unit

- Plug the cables of the Local Unit into the back of the CPU. (See Fig. 1.)
 - Connect the blue 15HD cable end to the VGA port on the back of the CPU.
 - Connect the black 3.5mm stereo plug into the "line out", "spkr", or "headphones" jack on the back of the CPU or other audio/video source (i.e. VCR, DVD player, etc.).

Notes:

If all 3 jacks are available, use the jack marked "line out".

The "line out" jack is typically lime green and may be marked with this symbol 

The "spkr" jack is typically orange, and may be marked with this symbol 

The "headphones" jack may be marked with this symbol 

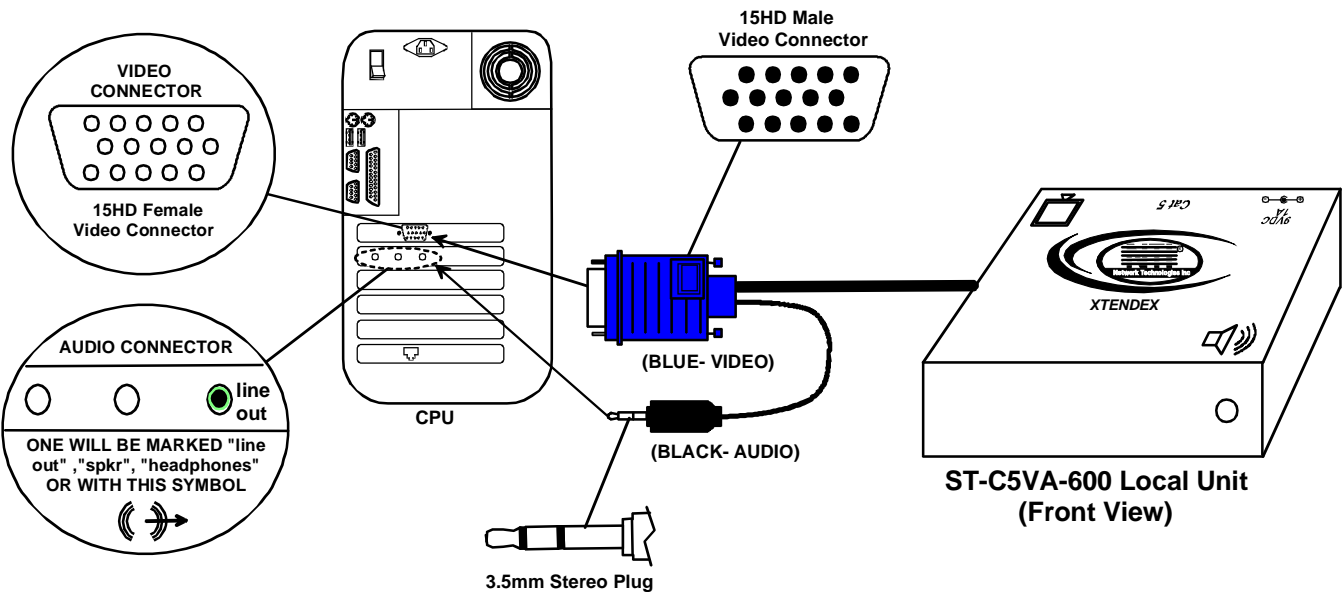

Figure 1- Connect the Local Unit to the CPU

2. Make connections for a Local User (see Fig. 2)
 - a) Connect the cable from the local user's VGA monitor to the female 15HD port on the Local Unit.
 - b) Connect the cable from the local speakers into the 3.5mm jack on the local unit.

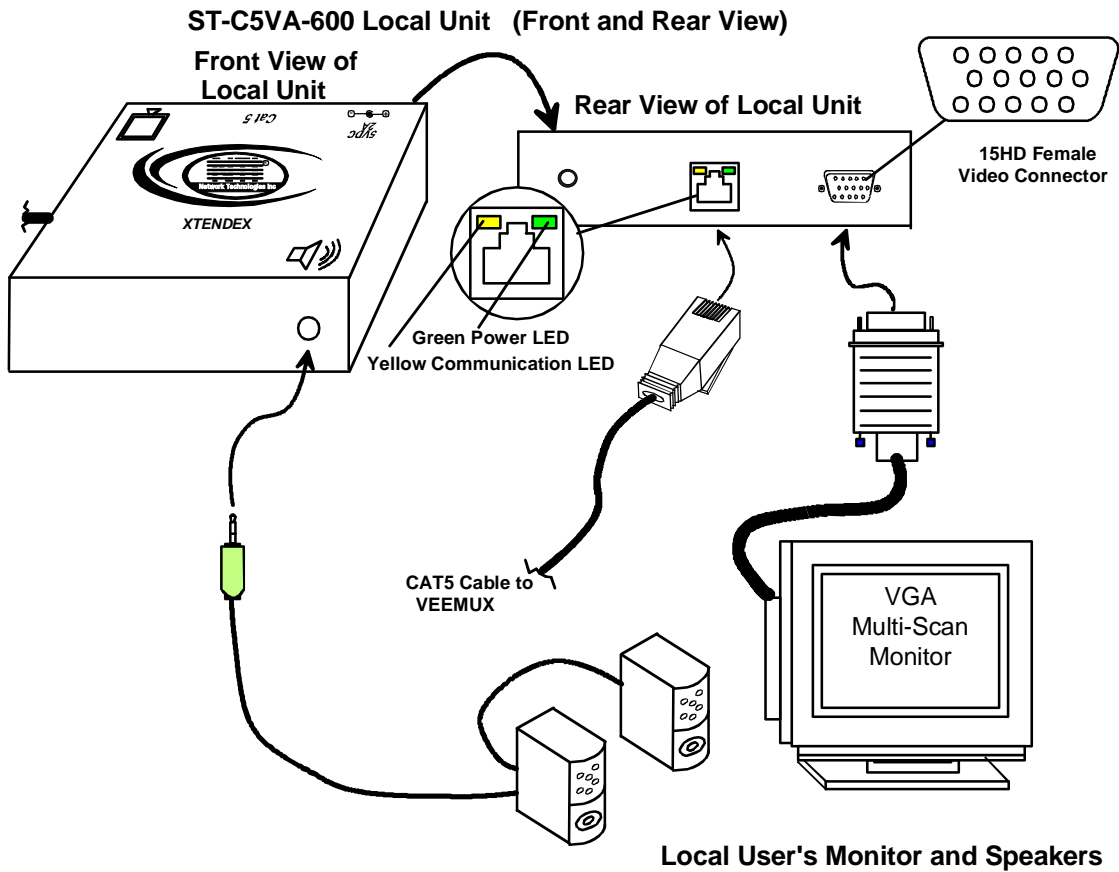

Figure 2- Connect Local User Components to Local Unit

3. Connect the CAT5 cable to the "Cat 5" port on the Local Unit. (See Fig. 2.) When properly inserted the cable end should snap into place.

Note: If an RJ45 wall outlet is being used, connect the other end of the extension cable to the RJ45 wall outlet.



WARNING: Never connect the ST-C5VA-600 Extender to an Ethernet card, Ethernet router, hub or switch or other Ethernet RJ45 connector of an Ethernet device. Damage to devices connected to the Ethernet may result.

The Remote Unit

1. Position the Remote Unit such that the CAT5 cable, the monitor cable, speaker cable, and the AC adapter power connector can each reach the Remote Unit comfortably.
2. Connect the monitor cable to the female 15HD video connector on the Remote Unit.
3. Connect the speakers to the 3.5mm jack on the Remote Unit (see Fig. 3).

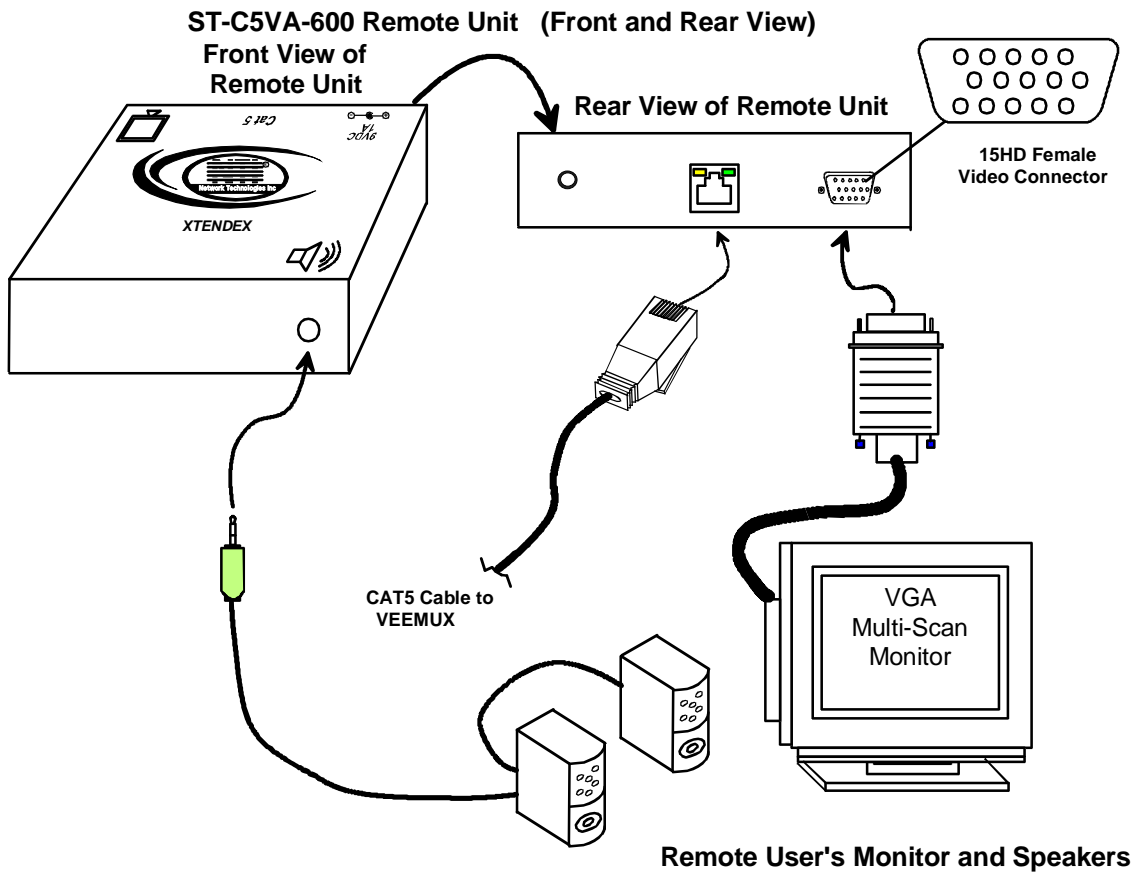

Figure 3- Connect the Extended Components to the Remote Unit

4. Connect the CAT5 cable to the “Cat 5” port on the Remote Unit. (See Fig. 3.) When properly inserted the CAT5 cable end should snap into place.

Note: If an RJ45 wall outlet is being used, connect the other end of the extension cable to the RJ45 wall outlet.



WARNING: Never connect the ST-C5VA-600 Extender to an Ethernet card, Ethernet router, hub or switch or other Ethernet RJ45 connector of an Ethernet device. Damage to devices connected to the Ethernet may result.

Plug-in and Boot Up

1. Plug the power cord from the monitor into the power outlet.
2. Connect each AC adapter power connector to the 9VDC ports on the Remote and Local Units. Make sure the power connectors go into each port all the way. Plug each AC adapter into a power outlet. The green LED on the RJ45 connector of both the Remote and Local Units should illuminate, indicating that a proper power connection has been made to them. (See Fig. 4.)

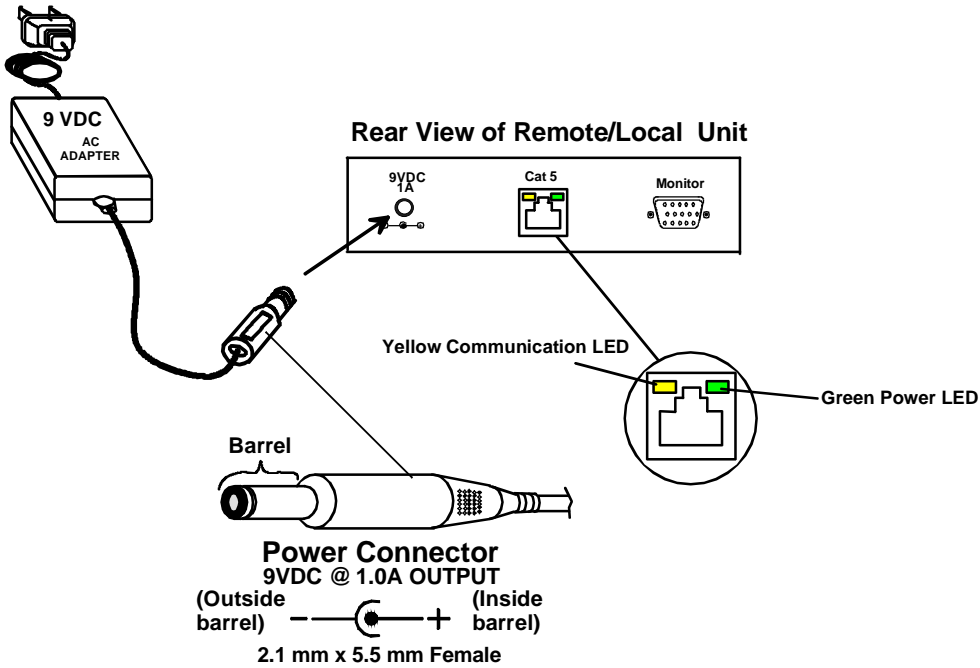

Figure 4- Connect the AC adapters

Note: The yellow LED on each RJ45 connector will blink anytime data traffic is passing between the Local and Remote Units, indicating proper CAT5 cable connection and communication. (See Fig. 4)

VEEMUX INSTALLATION

1. Connect an ST-C5VA-600 Local Unit to an audio/video source as described on pages 4-5.
2. Connect a CAT5 cable (wired as specified on page 27) between the ST-C5VA-600 Local Unit and VEEMUX connector "AV IN 1".

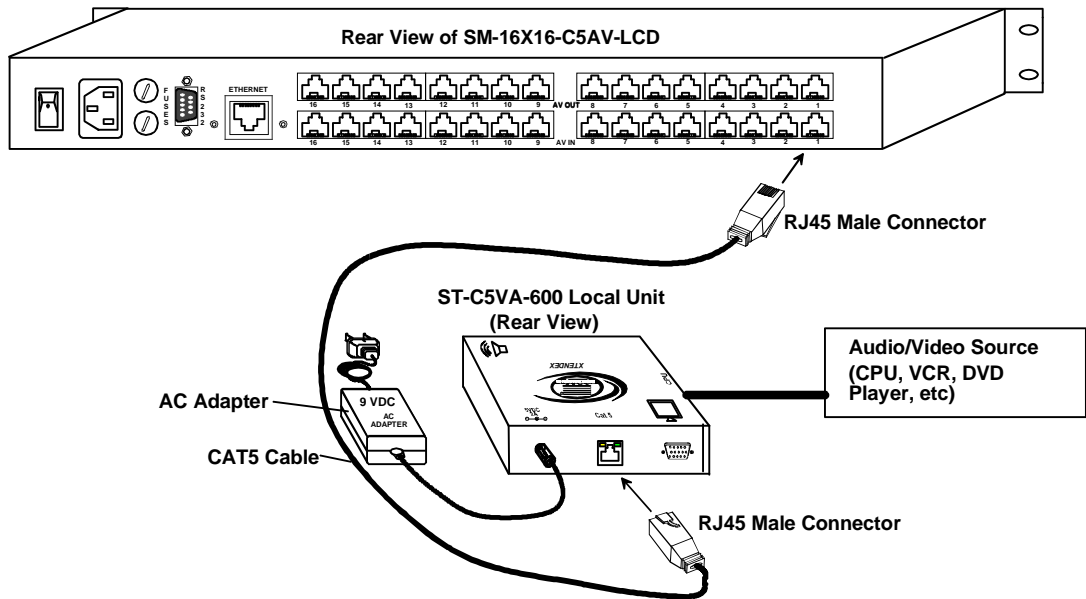

Figure 5- Attach ST-C5VA-600 Local Unit to VEEMUX

3. Connect a CAT5 cable (wired as specified on page 27) between an ST-C5VA-600 Remote Unit and VEEMUX connector "AV OUT 1".

Note: Shielded CAT 5,5e, or 6 cable must be used to connect to LOCAL and REMOTE units in order to meet CE emission requirements.

4. Connect a monitor and stereo speakers to the ST-C5VA-600 Remote Unit as described on page 6.
5. Connect the powercord as shown in Fig. 6.

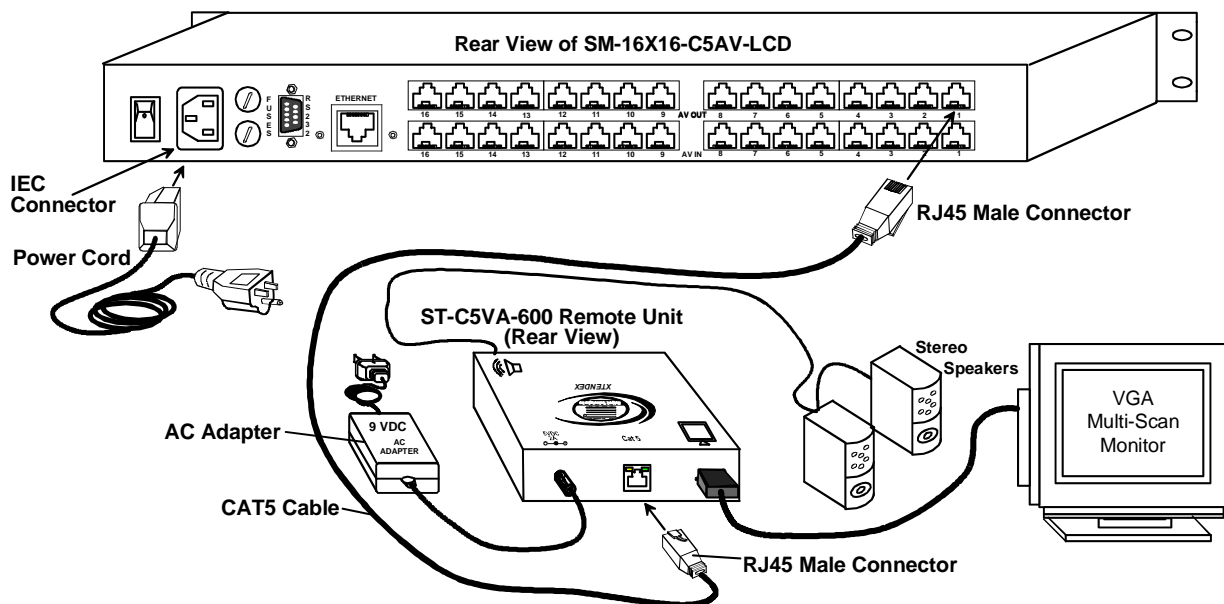

Figure 6- Attach ST-C5VA-600 Remote Unit to VEEMUX

Note: This total length of CAT5 cable between the ST-C5VA-600 Remote and Local units cannot exceed 600 feet. (See Fig. 9)

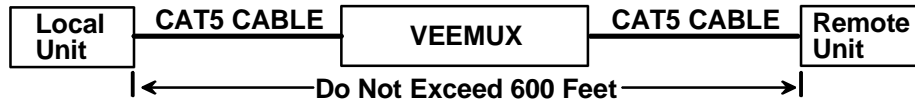

Figure 7- Maximum total CAT5 cable length cannot exceed 600 feet

6. To use the WEB Interface (page 20) , connect a CAT5 cable between the Local Network and the RJ45 connector on the VEEMUX labeled ETHERNET. (See Fig. 8) This cable should be wired straight through between two RJ45 connectors (pin 1 to pin 1, etc.)

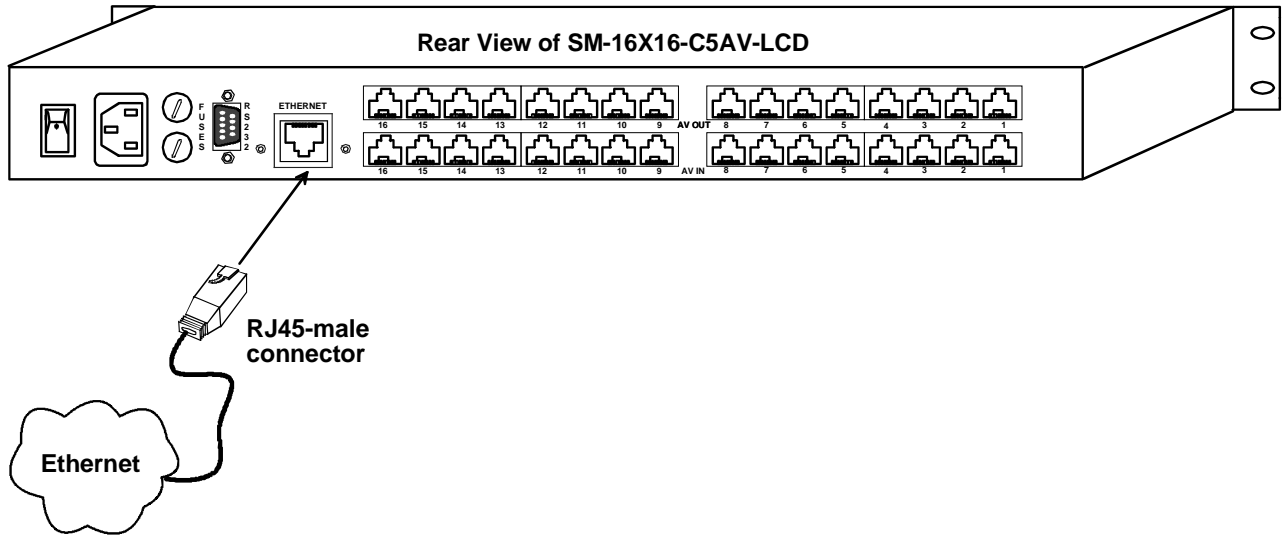

Figure 8- Connect VEEMUX to LAN

7. For direct connection of a user terminal, connect a male-to-female DB9 cable from a serial port on the terminal to the DB9 female connector on the VEEMUX. The cable should be wired straight through (pin 1 to pin 1, etc.) (See Fig. 9) The user terminal will control the VEEMUX via the RS232 interface (page 14). See page 30 for cable pinouts for PS/2, SUN, and MAC terminal connections.

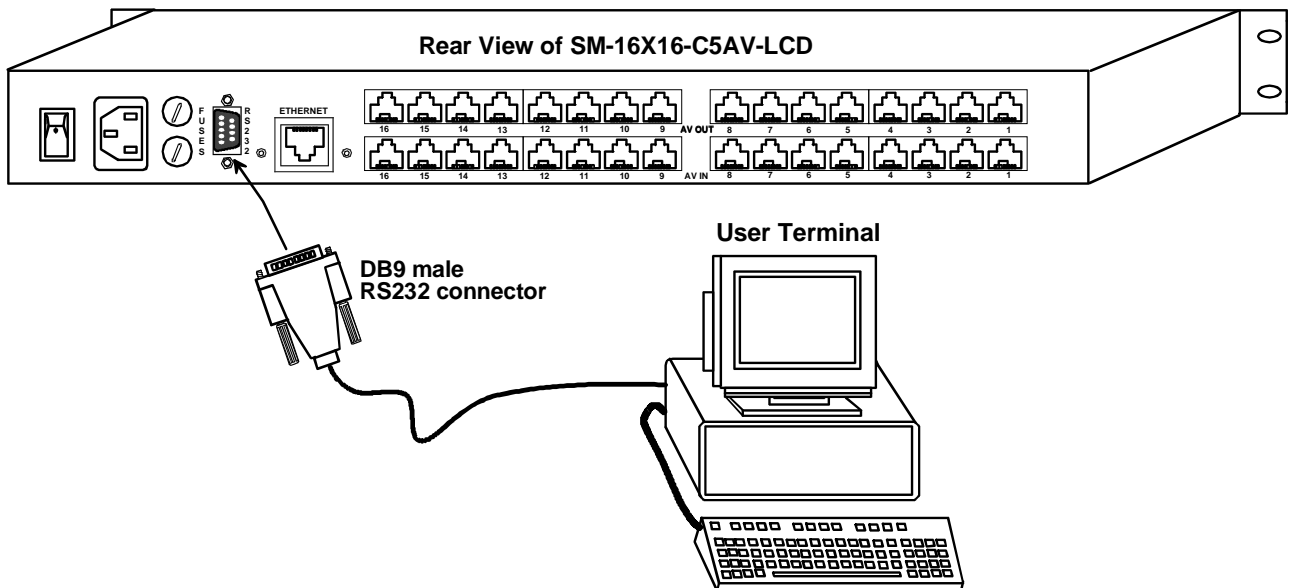

Figure 9- Connect user terminal to VEEMUX

USING THE VEEMUX SWITCH

The VEEMUX can be controlled by either of four methods:

- Using the keypad of the front panel interface
- Directly via an RS232 interface
- Remotely via web interface
- Remotely via telnet interface

Front Panel Interface Overview

On the front panel is an 18 push-button keypad and LCD that enable the user to operate the switch and change settings. (See Fig. 10)

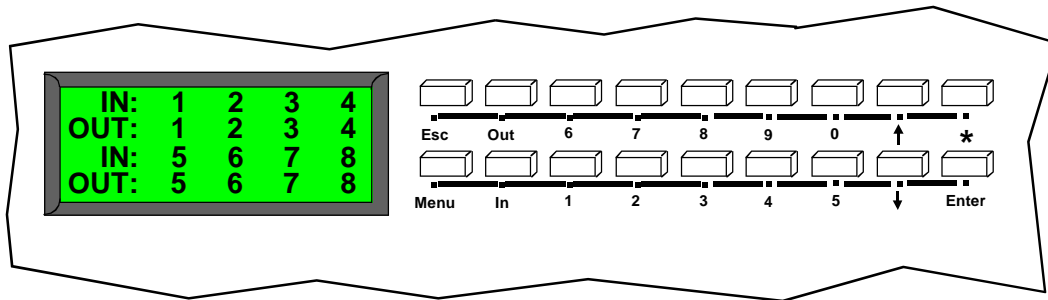

Figure 10- Front panel Interface LCD and keypad

After turning power ON, the LCD will show a start-up message for three seconds (see Fig. 11).



Figure 11- VEEMUX start-up message on LCD

During this time, the VEEMUX retrieves its switch settings from memory (the startup configuration is retrieved from stored configuration 0). Pressing any buttons during this time will have no effect. After 3 seconds, the switch will function normally and display the current configuration of connections. By default, the display will show all connections between Inputs and Outputs, displaying 8 at a time from the first to the last. Each set of 8 connections will display for 2 seconds, and the cycle will repeat indefinitely every 4 seconds.

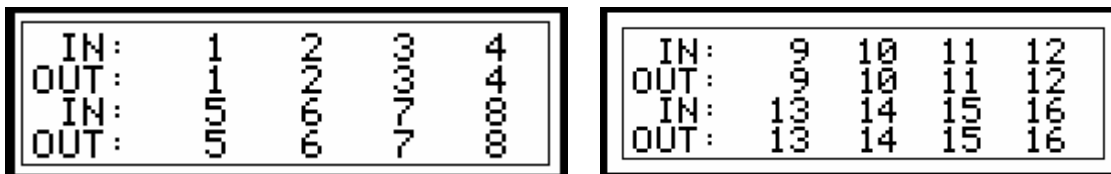



Figure 12- Connections screen on LCD, displays 8 sets at a time

Keypad Control

The front panel interface keypad and LCD enable the user to monitor switch status and route any user to any audio/video source (INPUT) on the switch. Along with the routing of the INPUTS to the user devices (OUTPUTS) the keypad and LCD allow the users to configure the RS-232 control interface and web server settings. The keypad buttons perform the following functions:

<u>Key</u>	<u>Action</u>
ESC	Cancel current action.
0 – 9	Used to enter numbers. (<i>n</i>)
In	The INPUT number can be entered (2 digits or 1 digit and ENTER) followed by the desired OUTPUT to be connected to (2 digits or 1 digit and ENTER).
Out	The OUTPUT number can be entered (2 digits or 1 digit and ENTER) followed by the desired INPUT to be connected to (2 digits or 1 digit and ENTER).
ENTER	Used to enter commands or values.
↑	Used to scroll menu up
↓	Used to scroll menu down
MENU	The Configuration Menu is displayed.
 *	Activate Memory Function- 10 memory locations (0 – 9), 0 is the power ON default. - to Save current connections * - In - <i>n</i> (0-9) - ENTER - to Recall connections * - Out - <i>n</i> (0-9) - ENTER Also used to enter the periods in a IP address or Subnet Mask

Configuration Menu

By pressing the Menu key the display will show the following configuration menu:

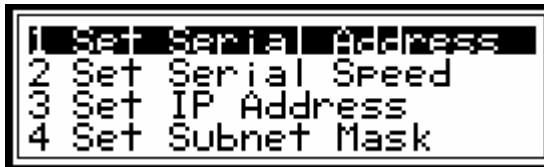

Figure 13- Configuration menu on LCD

The configuration menu includes the following items:

1. **Set Serial Address** – allows the user to change the serial address of the switch
2. **Set Serial Speed** – allows the user to change the baud rate
3. **Set IP address** – allows the user to change the IP address allocated to the switch
4. **Set Subnet Mask** – allows the user to change the subnet mask
5. **Set Default Gateway**- allows the user to change the default gateway used
6. **Set Wserver Timeout**- allows the user to change the web server access timeout period
7. **Adjust Contrast** – allows the user to change the contrast of LCD
8. **Video Adjustment** – allows the user to force a video quality adjustment
9. **Show Size** – allows the user to see the dimensions of the switch and status of the webserver

Only 4 items are visible at a time. To navigate through configuration menu items, the user will use the ↑ and ↓ button from keypad. The current item is highlighted. The user can select the current item by pressing the ENTER button. Alternatively, the user can directly select any item, by pressing the corresponding number (1 to 9) from the keypad.

Set Serial Address

When selecting this menu item, the display shows the current serial address and the user is prompted to introduce a new serial address. One or two digits can be entered followed by <Enter>. The display will prompt if the address is successfully changed. Pressing <Esc> will cancel this command. The serial address is used by the RS232 line to send commands. Valid addresses are between 1 and 99. The factory default address is 1.



Figure 14- Set Serial Address from LCD and keypad

Set Serial Speed

When selecting this menu item, the display shows the current serial speed (baud rate) and offers options to change to a different speed:

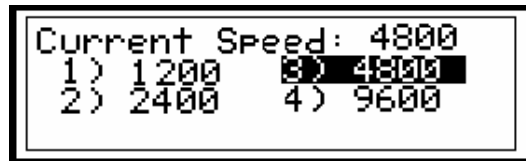

Figure 15- Set baud rate from LCD and keypad

The current option is highlighted. Move the highlight (by using arrow keys) to the desired speed and press <Enter> to apply. An alternative way is to press the number key that corresponds to desired speed (see Fig. 15).

To exit from this submenu, press <Esc>.

Available speeds are: 1200,2400,4800, and 9600 baud.

Factory default speed is 9600 baud.

Set IP Address

When selecting this menu item, the display shows the current IP address (default factory IP address is 192.168.1.1) and prompts the user to enter a new IP address. A new IP address is entered using number keys and the <*> key for periods. The user must press <Enter> to save the new IP address. If the new address is invalid, the user will be prompted, otherwise the display will indicate that the address was successfully changed.



Figure 16- Set IP Address from LCD and keypad

Set Subnet Mask

When selecting this menu item, the display will show the current subnet mask. A new subnet mask is entered using number keys and the <*> key for periods. The user must press <Enter> to save the new subnet mask. If the new subnet mask is invalid, the user will be prompted, otherwise the display will indicate that the subnet mask was successfully changed.

The default subnet mask is 255.255.255.0. This does not need to be changed for VEEMUX to work. If deemed necessary, the network administrator will change it .

Set Default Gateway

When selecting this menu item, the display will show the current default gateway. A new default gateway mask is entered using number keys and the <*> key for periods. The user must press <Enter> to save the new default gateway. If the new default gateway is invalid, the user will be prompted, otherwise the display will indicate that the default gateway mask was successfully changed.

The factory set default gateway is 192.168.1.0. This does not need to be changed for VEEMUX to work. If deemed necessary, the network administrator will change it .

Set Wserver Timeout

When selecting this menu item, the display shows the current webserver timeout period and offers optional values to change it to.



Figure 17- Wserver Timeout Period

The currently selected value is highlighted. Move the highlight (using the arrow keys) to the desired timeout value and press <Enter> to apply the value. An alternative method of selection is to press the number key that corresponds to the desired timeout value.

Available timeout period values include: 1,5,10,15, or 30 minutes, and 1,2,5, or 8 hours. The default timeout period is 1 hour.

To exit, press <Esc>.

Adjust Contrast

When selecting this menu item, the display shows a scroll bar with the current position of the LCD display contrast value. The user can change the contrast value using an arrow key from the Keypad. Pressing the up arrow will increase contrast while pressing down arrow will decrease it. The scroll bar will move according to the contrast value and the effects of contrast adjustments will be immediately visible on the LCD display.



Figure 18- Adjust LCD contrast

After adjusting the contrast the user can press <Enter> to store the new contrast value, or press <Esc> to return the contrast to its original value.

Video Adjustment

This allows the user to force a connection to an output and initiate the video quality adjustment to assure the image on the monitor is as clear as possible. This is useful when a CAT5 cable is changed without first switching the connection in the VEEMUX. Otherwise an automatic video quality adjustment is made whenever a new connection (Input to Output) is established and whenever VEEMUX is powered ON.

Show Size

This menu item allows the users to see the number of inputs and outputs available for the switch and the status of the webserver.

Displaying Audio Level (Digital VU-Meter)

To display the dynamic audio level (volume) of one of the outputs, the user should press <Esc> from the normal display mode (connection status). The following window will display the decibel level of left and right audio channels. The rightmost gradation on the scale corresponds to 0dB, and the leftmost -96dB.

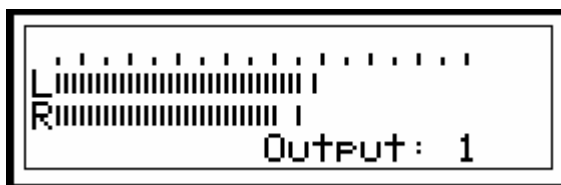

Figure 19- View Output audio level

To display the audio output level of a different Output port, type the number of the desired Output (1 or 2 digits) and press <Enter>.

This function is particularly useful to determine if a lack of sound from speakers is due to failed speakers, or lack of audio signal through the VEEMUX. If no signal is seen in this display, check all connections between the audio source, the XTENDEX, and the respective Input port on the VEEMUX.

Pressing <Esc> again will return to the connections display.

RS232 Interface

A user may control the VEEMUX using an RS232 interface by connecting a PC to the DB9 female connector on the VEEMUX labeled "RS232". Using a program such as HyperTerminal or the Matrix Switcher's Control Program (page 15), the VEEMUX can be setup and controlled.

When using HyperTerminal (or a similar program), configured at the same baud rate as in the VEEMUX (default is 9,600), 8 bits, no parity, no flow control, the VEEMUX can be controlled by sending the commands in the following chart, where:

SW = the Switch Serial Address
 <CR> = the Carriage Return character
 IP = the input port
 OP = the output port
 ip = the IP address

Command	Answer	Description
CS SW,IP,OP	*<CR>	Connect One Input (Audio/Video Source) to Output (User Port)
CA SW,IP	*<CR>	Connect All Outputs To Input
RO SW,OP	*<CR>IP<CR>	Read Connection For Output
CC SW,xx	*<CR>xx<CR>	Save Matrix Connections Into Memory Bank xx xx= 00-09
RC SW,xx	*<CR>xx<CR>	Restore Matrix Connections From Memory Bank xx Xx=00-09
CB 00,nn	none	Change baud rate of serial line, nn=12(00),24(00),48(00),96(00) Factory default is 9,600
RV SW,00	*<CR>string\0<CR>	Read NTI Version String
RU SW	*<CR>IP,OP<CR>	Read Unit Size
EA SW,ip	*<CR>	Set the IP address, ip is in xxx.xxx.xxx.xxx format, number of digits is minimum 1 and maximum 3 for each field Leading zeroes are accepted
EM SW,ip	*<CR>	Set the Subnet mask, ip is in xxx.xxx.xxx.xxx format, number of digits is minimum 1 and maximum 3 for each field. Leading zeroes are accepted
EG SW,ip	*<CR>	Set the default gateway, ip is in xxx.xxx.xxx.xxx format, number of digits is minimum 1 and maximum 3 for each field Leading zeroes are accepted
ET SW,timeout	*<CR>	Set the website timeout; timeout = numeric string of timeout in seconds. Values: 60, 300, 600, 900, 1800, 3600, 7200, 18000, 28800
RA SW	*<CR>ip<CR>	Read the IP address, ip is in xxx.xxx.xxx.xxx format, number of digits is minimum 1 and maximum 3 for each field Leading zeroes are accepted
RM SW	*<CR>ip<CR>	Read the Subnet mask, ip is in xxx.xxx.xxx.xxx format, number of digits is minimum 1 and maximum 3 for each field Leading zeroes are accepted
RG SW	*<CR>ip<CR>	Read the default gateway, ip is in xxx.xxx.xxx.xxx format, number of digits is minimum 1 and maximum 3 for each field Leading zeroes are accepted
RT SW	*<CR>timeout<CR>	Read the website timeout; timeout = numeric string of timeout in seconds. Values: 60, 300, 600, 900, 1800, 3600, 7200, 18000, 28800

If the first field is not a known command (as listed above) or SW field is different from the serial address programmed in the switch memory, the command will be ignored. If the SW field corresponds to the serial address, but the syntax is wrong after this field, the switch will answer with ?<CR>.

Matrix Switcher's Control Program For Windows 9X, NT, 2000 and XP

The Matrix Switcher's Control Program is an easy and powerful graphical program that controls NTI matrix switches through an RS232 interface from an attached PC. The Matrix Switcher's Control Program is included on the CD packaged with the VEEMUX. The Matrix Switcher's Control Program is downloaded by clicking on the link "Download Matrix Switcher's Control Program".

To install the Matrix Switcher's Control Program after downloading

1. Locate the **Setup.exe** in the directory the program was downloaded to and double-click on it
2. Follow the instructions on the screen

The Matrix Switcher's Control Program performs best on monitors set to a screen resolution of at least 800 X 600. Instruction for using the Matrix Switcher's Control Program is available by opening "MSCP Help" in the "NTI" program group once the program has been installed and is open on the screen.

To open "MSCP Help" from the Windows desktop

1. Click on **START**
2. Click on **PROGRAMS**
3. Click on **NTI**
4. Click on **MSCP Help**

Telnet Interface-Port 2000

The Telnet Interface enables the user to control the switch using telnet client through an Ethernet connection. The telnet server listens on **ports 2000 and 2005**. Port 2000 is for an operator telnet session while port 2005 (must be enabled) is intended for a software control type session (see page 17). For operator telnet control using the telnet interface and the current IP address, type the following in a command shell:

telnet 192.168.1.1 2000

The VEEMUX will prompt the user for a password. The user must enter the password followed by <Enter>.

The default factory password is "admin".

With a proper password sent the VEEMUX will respond with:

***Password Successful
Connection Established***

The following commands are now available:

Command	Reply	Description
H(elp) or h(elp)	Displays the list of commands	Help
<Ctrl>-<X> (see note 4 below)	Good Bye. Connection to host lost.	Quit telnet session
CS nn,mm	*<CR>	Connect one Input Port (nn) To one Output Port (mm)
CA nn	*<CR>	Connect All Outputs To Input
RO nn	*<CR>mm<CR>	Read Connection For Output. Returns the number of the input (mm) connected to output nn
CC nn	*<CR>nn<CR>	Save Matrix Connections Into Memory Bank nn nn should be between 00 and 09
RC nn	*<CR>nn<CR>	Restore Matrix Connections From Memory Bank nn nn should be between 00 and 09
CB nn	*<CR>	Change baud rate of serial line, nn=12(00),24(00),48(00),96(00) Factory default is 9,600.
RV 00	*<CR>string\0<CR>	Read NTI Version String
RU	*<CR>nn,mm<CR>	Read Unit Size Returns the number of inputs(nn) and the number of outputs (mm)
CP	User is prompted to introduce the password twice	Change password

Notes:

1. The commands must be typed exactly as shown in the chart. The commands are case sensitive.
2. If a mistake is made, the user must backspace to the beginning and completely retype the command.
3. If a command is sent that the VEEMUX does not recognize or exceeds the configuration of the switch, the reply "?" may be received. Check the command syntax and try again.
4. To quit the telnet session, press the keyboard keys <Ctrl><X> .

Telnet Interface-Port 2005

For a software control type of telnet interface session (versus operator telnet control through port 2000 as described on page 16), connect to the VEEMUX through the current IP address at port 2005. To do this, a connection to port 2005 must first be enabled (see Web Setup on page 23). Then, with port 2005 enabled, use the command set below to control and acquire information from the VEEMUX.

Notes:

- *If Port 2005 connection is idle for 10 seconds it will disconnect*
- *Up to 2 active connections are allowed at the same time*
- *After establishing the connection, the unit will answer with *<CR>. If the connection fails or there are already 2 connections established, it will answer with ?<CR>*

Command Summary

Command String	Good Response	Description
RU<CR>	ru OP,IP<CR>	Read unit size
RO OP<CR>	pc OP,IP<CR>	Read connection for OP
CS OP,IP<CR>	*<CR>	Connect OP to IP
CA IP<CR>	*<CR>	Connect all outputs to IP
SS 01<CR>	*<CR>	Enable auto-status mode
SS 00<CR>	*<CR>	Disable auto-status mode
SX<CR>	See details	Examine connections
XX<CR>	*<CR>	Close connection

A <CR> (carriage return, 0x0D) is considered to be the end of the command string. If a string exceeds 16 characters, an end of string will be inserted automatically to avoid buffer overflow. An eventual <LF> (line feed, new line, 0x0A) after a <CR> will be ignored. A bad string will always be responded to with the ASCII character '?' followed by a <CR>.

Command Detail

RU-Read Unit Size

Command:

Byte 1	Byte2	Byte3
'R'	'U'	<CR>
(0x52)	(0x55)	(0x0D)

Response:

Byte 1	Byte 2	Byte 3	Byte 4	Byte 5	Byte 6	Byte 7	Byte 8	Byte 9
'r'	'u'	Space	Output – 1st digit	Output-2nd digit	','	Input – 1st digit	Input – 2nd digit	<CR>
(0x72)	(0x75)	(0x20)	(0x30...0x32)	(0x30...0x39)	(0x2C)	(0x30...0x32)	(0x30...0x39)	(0x0D)

This command will read the size of the unit. The response returns the number of inputs and the number of outputs in two-digit, ASCII code format. If the numbers are smaller than 10, the 1st digit is '0'.

RO-Read Connection for Output Port

Command:

Byte 1	Byte 2	Byte 3	Byte 4	Byte 5	Byte 6
'R'	'O'	Space	Output – 1st digit	Output – 2nd digit	<CR>
(0x52)	(0x4F)	(0x20)	(0x30...0x32)	(0x30...0x39)	(0x0D)

Response:

Byte 1	Byte 2	Byte 3	Byte 4	Byte 5	Byte 6	Byte 7	Byte 8	Byte 9
'p'	'c'	Space	Output – 1st digit	Output-2nd digit	','	Input – 1st digit	Input – 2nd digit	<CR>
(0x70)	(0x63)	(0x20)	(0x30...0x32)	(0x30...0x39)	(0x2C)	(0x30...0x32)	(0x30...0x39)	(0x0D)

This command will read the connection of an output port. The response returns the output port that is connected to the input port.

CS- Connect Output Port to Input Port

Command:

Byte 1	Byte 2	Byte 3	Byte 4	Byte 5	Byte 6	Byte 7	Byte 8	Byte 9
'C' (0x43)	'S' (0x53)	Space (0x20)	Output – 1st digit (0x30...0x32)	Output – 2nd digit (0x30...0x39)	',' (0x2C)	Input –1st digit (0x30...0x32)	Input –2nd digit (0x30...0x39)	<CR> (0x0D)

Response:

Byte 1	Byte 2
'*' (0x2A)	<CR> (0x0D)

This command connects the specified input port to the specified output port.

CA- Connect All Output Ports to Input Port

Command:

Byte 1	Byte 2	Byte 3	Byte 4	Byte 5	Byte 6
'C' (0x43)	'A' (0x41)	Space (0x20)	Input – 1st digit (0x30...0x32)	Input - 2nd digit (0x30...0x39)	<CR> (0x0D)

Response:

Byte 1	Byte 2
'*' (0x2A)	<CR> (0x0D)

This command connects all output ports to the specified input port.

SS_01- Enable Auto Status Mode

Command:

Byte 1	Byte 2	Byte 3	Byte 4	Byte 5	Byte 6
'S' (0x53)	'S' (0x53)	Space (0x20)	'0' (0x30)	'1' (0x31)	<CR> (0x0D)

Response:

Byte 1	Byte 2
'*' (0x2A)	<CR> (0x0D)

Auto status mode is disabled by default whenever the connection is established, and this command must be entered to enable it. When auto status mode is enabled, a message will be sent whenever an input/output connection changes from any source. The format of this message is given in the table below. The first two numeric digits are the output port number and the two after the colon are the number of the input port that is now connected to it.

Byte 1	Byte 2	Byte 3	Byte 4	Byte 5	Byte 6	Byte 7	Byte 8	Byte 9
'p' (0x70)	'c' (0x63)	Space (0x20)	Output – 1st digit (0x30...0x32)	Output – 2nd digit (0x30...0x39)	':' (0x3A)	Input – 1st digit (0x30...0x32)	Input – 2nd digit (0x30...0x39)	<CR> (0x0D)

SS_00- Disable Auto Status Mode

Command:

Byte 1	Byte 2	Byte 3	Byte 4	Byte 5	Byte 6
'S' (0x53)	'S' (0x53)	Space (0x20)	'0' (0x30)	'0' (0x30)	<CR> (0x0D)

Response:

Byte 1	Byte 2
'*' (0x2A)	<CR> (0x0D)

This command disables auto status mode.

SX- Examine connections

Command:

Byte 1	Byte 2	Byte 3
'S' (0x53)	'X' (0x58)	<CR> (0x0D)

Response:

Multiple lines, one line for each output:

Byte 1	Byte 2	Byte 3	Byte 4	Byte 5	Byte 6	Byte 7	Byte 8	Byte 9
'p' (0x70)	'c' (0x63)	Space (0x20)	Output – 1st digit (0x30...0x32)	Output – 2nd digit (0x30...0x39)	':' (0x3A)	Input – 1st digit (0x30...0x32)	Input – 2nd digit (0x30...0x39)	<CR> (0x0D)

Byte 1	Byte 2	Byte 3	Byte 4	Byte 5	Byte 6	Byte 7	Byte 8	Byte 9
'p' (0x70)	'c' (0x63)	Space (0x20)	Output – 1st digit (0x30...0x32)	Output – 2nd digit (0x30...0x39)	':' (0x3A)	Input – 1st digit (0x30...0x32)	Input – 2nd digit (0x30...0x39)	<CR> (0x0D)

Last line:

Byte 1	Byte 2
'*' (0x2A)	<CR> (0x0D)

Terminate telnet session

Command:

Byte 1	Byte 2	Byte 3
'X' (0x58)	'X' (0x58)	<CR> (0x0D)

Response:

Byte 1	Byte 2
'*' (0x2A)	<CR> (0x0D)

The unit will respond with '*<CR>' and close the connection, terminating the telnet session. The unit is then available for future connections.

Web Interface

A user may control the connections of the VEEMUX using a Web Interface via any web browser (see page 1 for web supported browsers). With the VEEMUX connected to a LAN through an Ethernet cable, a user can access the web interface controls inside the VEEMUX.

FYI: To quickly locate a VEEMUX on the LAN and edit the IP address settings, use the Device Discovery Tool (page 26).

To access the web interface, type the current IP address into the address bar of the web browser.

Address

To open a SSL-encrypted connection, type:

Address

You will be prompted to accept a certificate. Accept the NTI certificate.

A "Welcome Page" will appear.



Figure 20- Web interface Welcome page

Enter the Password

Click on a link to the left to be prompted for a username and password.

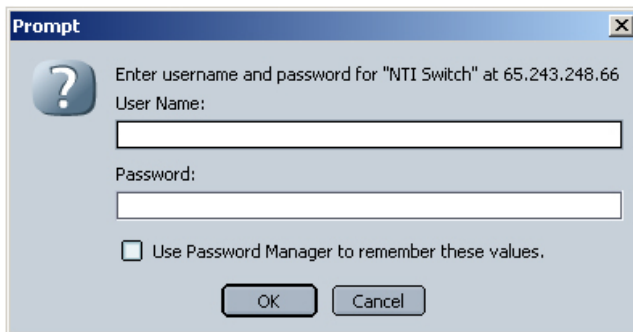

Default User Name = Administrator
 (upper case letter for "A" only)
Default Password = admin (lower case letters only)

Note: The browser must be configured to accept cookies in order for the user to successfully make use of the web interface.

Figure 21- Web interface Login Prompt

As described on the following pages, each link will enable different areas of control for the VEEMUX.

Switch Page

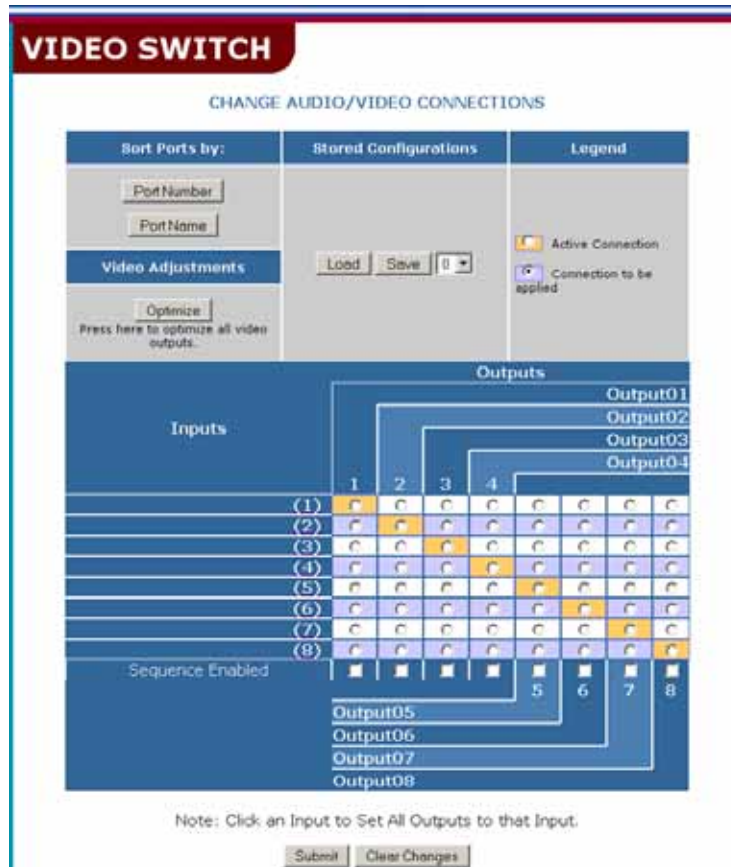

Figure 22- Web interface Switch page

The Switch page (above) displays the active connections (shown in orange). This page enables the user to manually control the connections of the VEEMUX. Up to 10 different connection configurations can be saved and later recalled by any connection method.

Note: Configuration 0 will be automatically loaded when the VEEMUX is powered up.

To change a connection, click on the radio button (square image with circle in the center) that intersects the input and output columns. A black dot will be placed in the circle to indicate the selection. Then press the **Submit** button. The display will be reloaded with the selections changed to orange to indicate they are now active. Multiple connections can be changed simultaneously.

To quickly clear the selected radio buttons press the **Clear Changes** button. This will only work if the **Submit** button has not already been pressed with the selections made.

The **Sequence Enabled** blocks indicate the status of the Scan Sequence function (page 25) for each output. If a scan sequence for an output is enabled (checkmark in box), it will automatically be disabled if the connection is manually changed. To re-enable the scan sequence from the Switch page, place a checkmark in the box for the desired output and press **Submit**.

To quickly connect all outputs to a single input, choose the desired input from the "Set all Outputs to Input" drop-down list and press the **Submit** button.

Note: If radio buttons are selected in addition to using the "Set all Outputs to Input" option, the selections made by the "Set all Outputs to Input" will take precedence when the Submit button is pressed. Selections that conflict with it will be ignored.

To save a configuraton, from the **Stored Configurations** user interface, use the drop-down list to select the desired slot (numbers 0-9) to save the active configuration into and press the **Save** button.

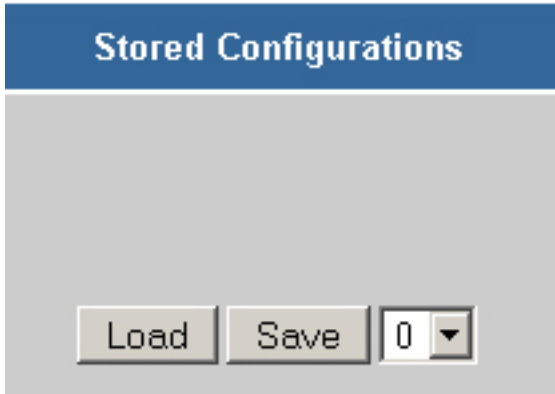

Note: This will save the currently active configuration on the VEEMUX. If changes have been made in the web interface without first pressing the Submit button, those changes will not yet be part of the active configuration.

Note: If changes to the active configuration have been made by another user prior to saving the current connection selections, the changes made by the other user will be saved as the configuration.

The webpage configuration that loads after a **Save** is the configuration that was actually saved.

To load a saved configuration, from the **Stored Configurations** user interface, use the drop-down list to select the desired configuration. Then press the **Load** button. The VEEMUX will make the connections and the screen will refresh to show the connections associated with that configuration selection.

To adjust video quality, from the **Video Adjustment** user interface, press the **Optimize** button. This will force the VEEMUX to adjust video signal levels to achieve maximum video quality on all connected monitors.

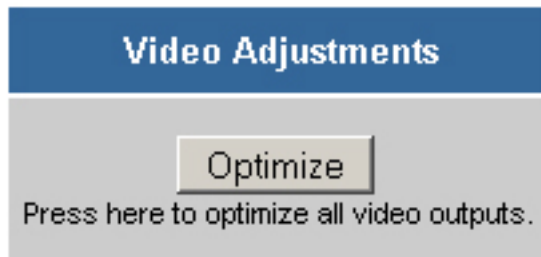

Setup Pages

These settings enable the user to configure the VEEMUX web interface connection.

- This change will take a few seconds and automatically redirect the user to the IP address specified.

Note: Since the webserver will be restarting all active connections will be logged out.

The Website Timeout option controls how long an inactive web connection will stay logged in. Any change to the Website Timeout configuration takes effect immediately.

The "Telnet configuration" block enables the VEEMUX to receive commands on port 2005 in addition to port 2000. For more on telnet use, see "Telnet Interface- Port 2000" on page 16.

Note: The VEEMUX must be power cycled in order for a change in the Telnet configuration block to take effect.

IP Address Configuration	Current IP Address	192.168.1.1
Subnet Mask Configuration	Current Subnet	255.255.255.0
Default Gateway Configuration	Current Gateway	192.168.1.1
Website Timeout	Current Timeout	1 Hour
Telnet configuration	Enable telnet connection on port 2005	<input checked="" type="checkbox"/>

Save Reset Form

Copyright © 2004 NTI. All rights reserved.

Figure 23- Web interface Setup page

Serial Address Configuration	Current Address	1
Serial Speed Configuration	Current Speed	9600

Save Reset Form

Copyright © 2004 NTI. All rights reserved.

Figure 24- Web interface Serial Setup page

The Serial Address and Serial Speed (Fig. 24) do not require a reset and will take effect immediately.

Video Input Names

The Video Input Names page enables the Administrator to change the name of the input ports displayed on the Switch page. To change a Video Input Name, enter the name of the input port for the desired port number, and press **Save**.

Note: Only the changes to the input port directly to the left of the Save button will be saved. All other changes to input ports without pressing the port's respective Save button will be discarded. All input port names must be no more than 12 characters in length and only alphanumeric characters may be used.

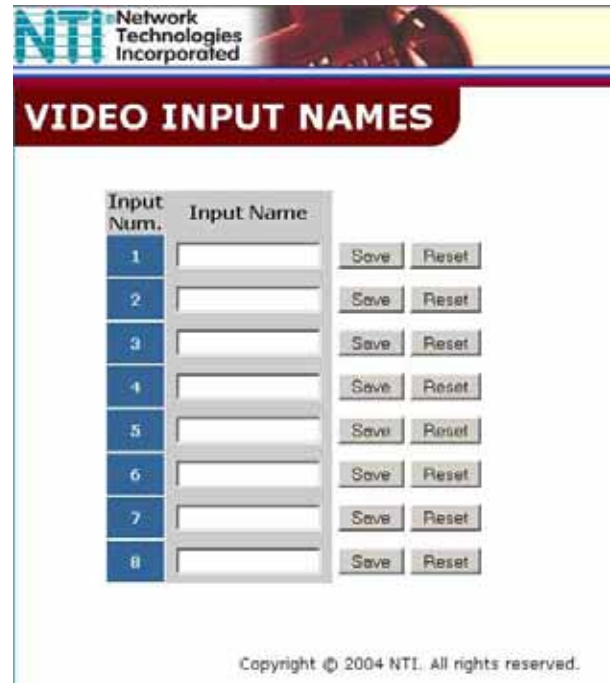

Figure 25- Web interface Video Input Names page

Video Output Names

From the Administration menu, the Video Output Names page can be displayed. This page enables the Administrator to change the names of the output ports displayed on the Switch page. To change a Video Output Name, enter the name of the port for the desired output port number, and press **Save**.

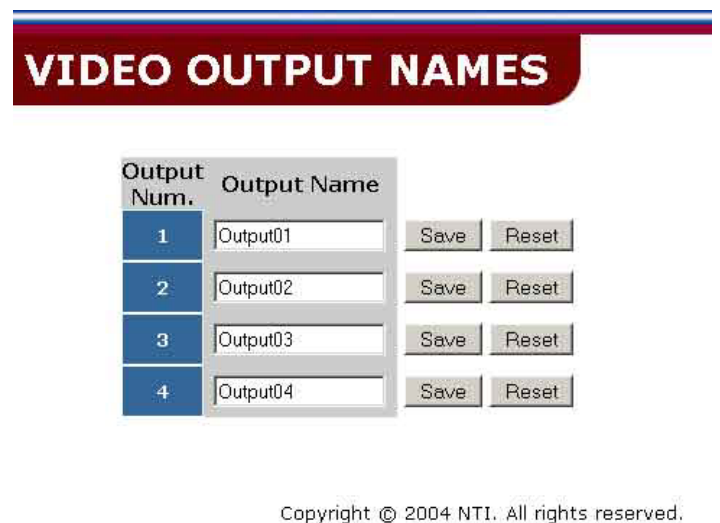

Figure 26- Web interface Video Output Names page

Outputs Scanning Sequences

Input	Sequence	Dwell Time (in seconds)
(1)	On	5
(2)	Off	0
(3)	On	15
(4)	On	20
(5)	On	25
(6)	Off	0
(7)	On	35
(8)	On	40

Figure 27- Outputs Scanning Sequences page

The Outputs Scanning Sequences page displays the configuration of an automatic switching sequence from input (video source) to input for each output (monitor).

The page displays:

- output number being configured
- the Scanning Sequence function status for that output
- the Scan Mode status of each input (ON/OFF)
- the length of time in seconds (dwell time) that each input will be viewed when connected

The output selection at the top of the page can be changed to any output to display the Scan Sequence Input selections and dwell times for that output.

The inputs and the amount of time that each will be viewed (0-255 seconds) can be set to cycle sequentially for each connected output. If an input is set to 0 seconds, the sequence status will display “OFF”, and the input will be omitted from the scanning sequence. To include an input in the sequence, enter a dwell time period from 1-255 seconds, and press **Apply**.

To quickly clear all dwell time settings, press the **Clear All** button at the bottom of the page. All sequence settings will change to “OFF” and all dwell time settings will change to 0.

To enable the scanning sequence for the output shown, place a checkmark in the “Sequence Enable” block.

Tip: To quickly enable the scan sequence for multiple outputs, use the “Sequence Enable” blocks found on the Switch Page (page 18).

Note: If only 1 input is set to Sequence “ON”, then the output connection to that input will not change when the Scanning Sequence is enabled.

Update Firmware

UPDATE FIRMWARE

Caution! You have asked to update the firmware.
Failure to update firmware properly can permanently damage the product.

[Please read these instructions](#) before proceeding.

Select the firmware update file

Firmware Revision: 1.10
Revision Date: 2007/01/05 16:59:01

Figure 28- Web interface Update Firmware page

The Update Firmware page shows the current version of the firmware and enables the Administrator to update the firmware of the VEEMUX.

WARNING: Failure to carefully follow these directions can permanently damage the VEEMUX. Please read these directions in full before continuing. Do not, under any circumstances, reset or power-down the VEEMUX while the firmware is being updated. Do not attempt to update the firmware if a power-failure is likely.

Note: The Firmware can only be updated from the non-secure (http) website. If you attempt to access this page from the secure (https) website, you will be automatically redirected to the non-secure site.

To update the firmware:

1. Contact NTI for the latest firmware file and copy it to your computer.
2. On the Update Firmware page, browse to the firmware file.
3. Press *Update Firmware*.
4. Wait for the following message to appear (may take several minutes):

*Upload Succeeded
Flash of new image completed:
The system will automatically restart.*

5. The VEEMUX will restart itself in 10 seconds, logging out all connections. After approximately 40 seconds, the VEEMUX will be ready to resume operation.

If a message appears stating that the Upload has failed, or that a non-fatal error has occurred:

1. Ensure that the file being uploaded is the NTI firmware file.
2. Repeat the process from step 2 above.

Note: This message does not indicate that damage to the product has occurred.

If a message appears stating that there has been a fatal error:

1. **DO NOT RESET OR POWER-DOWN THE VEEMUX.**
2. Repeat the update process from the first step 2 above.
3. If you get another Fatal Error message, call NTI tech-support at 1-800-742-8324 or 330-562-7070.

FYI: The VEEMUX should continue to run normally unless it is reset. However, damage may have occurred to the web server firmware that will prevent the product from starting up correctly.

Change Password Page



NTI Network Technologies Incorporated

CHANGE PASSWORD

CHANGE PASSWORD

Current Password	<input type="text"/>
New Password	<input type="text"/>
Confirm New Password	<input type="text"/>

Copyright © 2004 NTI. All rights reserved.

Figure 29- Web interface Password page

Use this page to change the password for accessing the web interface. (This password is also used for the telnet interface.) Be sure to make note of the new password exactly as it is case sensitive. The password must be between 5 and 16 characters in length and can be alphabetical or numeric.

Help Page

This page explains the purpose of each of the other pages in the VEEMUX web interface.

Update Web Server

Click on this selection to globally update the Web Server to any settings that have been changed though Telnet, the RS232 interface, or via the front panel of the VEEMUX. All users presently connected will be disconnected and must log back in after using this command.



Figure 30- Updating the Web Server

Logout Page



Figure 31- Web interface Logout page

This page will enable the user to end the session and close the web interface connection. Click on the "Press Here to Continue Logout" button to exit the VEEMUX web interface.

Note: *The connection will timeout automatically after a preset period of inactivity, configurable on the Web Setup page.*

DEVICE DISCOVERY TOOL

In order to easily locate the VEEMUX on a network, or change network settings, the NTI Device Discovery Tool may be used. A link to the Discovery Tool is provided on the web page that appears when you insert the instruction manual CD into your CD ROM drive. Click on the link or browse the CD and click on the file *discover.html*. This will open your browser and display the Device Discovery Tool page.

Note: The Discovery Tool requires the Java Runtime Environment to operate. A link to the web page from which it can be downloaded and installed is provided on the CD.

Note: The computer using the Discovery Tool and the VEEMUX must be connected to the same physical network in order for the Device Discovery Tool to work.

Network Technologies Inc Device Discovery Tool

- **START**
 - When you load this page, the NTI Device Discovery Applet should load. Accept the Certificate to allow this applet access to your network. Press the button entitled **Detect NTI Devices** to start the discovery process. After a short time, the tool will display all NTI devices on your network, along with their network settings.

Note: Do not close this page while the NTI Discovery Tool is running. Close the NTI Device Discovery Application first, **then** this webpage.
- **How To Use the Discovery Tool**
 - **To Change A Device's Settings**, within the row of the device whose setting you wish to change, type in a new setting and press the **Enter** key or the **Submit** button on that row. You can also press the **Submit All** button to submit all changes at once.
 - **To Refresh the list of devices**, press the **Refresh** button.
 - **To Blink the LEDs of the unit**, press the **Blink LED** button (This feature not supported on all products). The **Blink LED** button will change to a **Blinking...** button. The LEDs of the unit will blink until the **Blinking...** button is pressed, or the NTI Device Discovery Application is closed. The LEDs will automatically cease blinking after 2 hours.
 - **To Stop the LEDs of the unit blinking**, press the **Blinking...** button. The **Blinking...** button will change to a **Blink LED** button.

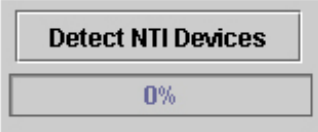

The image shows a screenshot of the Device Discovery Tool interface. It features a button labeled 'Detect NTI Devices' and a progress bar below it showing '0%'.

Figure 32- Device Discovery Tool page

Use the Device Discovery Tool to display all NTI VEEMUX devices on your network, along with their network settings. Follow the instructions on the Device Discovery Tool page to use the tool and to change the device settings if so desired.

INTERCONNECTION CABLE WIRING METHOD

CAT5 Cable

The connection cable between the VEEMUX and XTENDEX remote and local units is terminated with RJ45 connectors and must be wired according to the EIA/TIA 568 B industry standard. Wiring is as per the table and Fig. 33 below.

Pin	Wire Color	Pair	Function
1	White/Orange	2	T
2	Orange	2	R
3	White/Green	3	T
4	Blue	1	R
5	White/Blue	1	T
6	Green	3	R
7	White/Brown	4	T
8	Brown	4	R

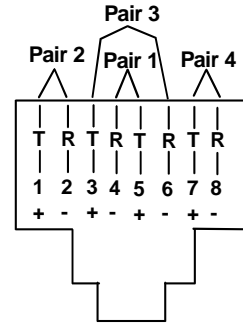

Figure 33- View looking into RJ45 female

Serial Cables

Pinout of RS232 port on VEEMUX

The VEEMUX RS232 serial port is a DB9 female connector configured as a DCE (data communications equipment) port. The RS232 port interface signals are listed below, including equivalent CCITT V.24 identification, and signal direction:

DB9F pin #	Common name	EIA name	CCITT name	Function	Direction
1	DCD	CF	109	Not used	--
2	TxD	BA	103	Transmit Data	Output
3	RxD	BB	104	Receive Data	Input
4	DTR	CD	108.2	Not used	--
5	SG	AB	102	Signal Ground	--
6	DSR	CC	107	Not used	--
7	CTS	CB	106	Not used	--
8	RTS	CA	105	Not used	--
9	RI	CE	125	Not used	--

Pinouts for typical DCE to DTE device cable for CPU connection

VEEMUX (DCE) to 9 PIN DTE (PS2 or SUN)

VEEMUX 9 pin		Signal Direction	PS/2 or SUN CPU 9 pin	
Function	Pin #		Pin #	Function
RxD	3	←	3	TxD
TxD	2	→	2	RxD
SG	5	—	5	SG

VEEMUX (DCE) to 25 PIN DTE (MAC)

VEEMUX 9 pin		Signal Direction	MAC CPU 25 pin	
Function	Pin #		Pin #	Function
RxD	3	←	2	TxD
TxD	2	→	3	RxD
SG	5	—	7	SG

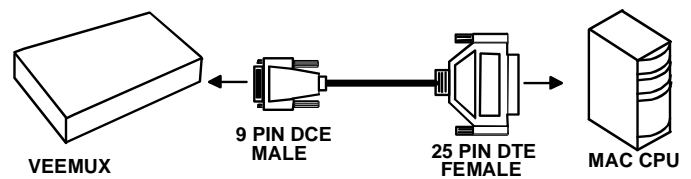
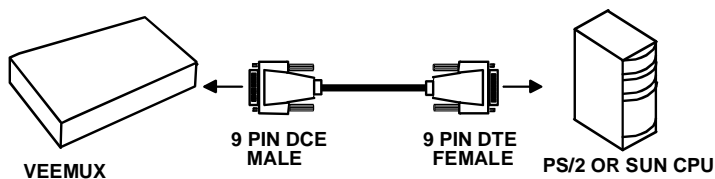

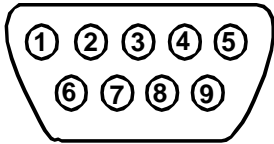

**Mating Face
of a DB9 Male**

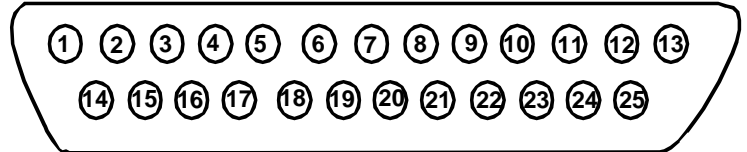

Mating Face of DB25 Male

TROUBLESHOOTING

- PROBLEM:** No audio
SOLUTION: Check all connections and power to all devices. Use the VU-Meter to determine if audio is passing through the VEEMUX
- PROBLEM:** Video not crisp & clear
SOLUTION: Force video quality adjustment (see page 13)
- PROBLEM:** No Video
SOLUTION: Check cable connections, power to all devices, and CAT5 cable wiring (if cables were terminated by the customer)
- PROBLEM:** Telnet or webserver not working
SOLUTION:
- Check indicator LEDs on the back of the unit.
 - Is there a valid connection? If not, check all cable connections.
 - Does the data light illuminate? Make sure the IP address is correct.
 - Ensure local network connection supports and is configured for 10baseT.
- PROBLEM:** RS232 control not working
SOLUTION: Wrong serial address. Verify the address of the unit that will not communicate. Check all cable connections.

APPENDIX

Appendix A- Default Settings

SETTING	DEFAULT VALUE
Login Username	Administrator (case sensitive)
Login Password	admin (case sensitive)
Serial Speed	9,600 bps
Serial Address	01
IP Address	192.168.1.1
Subnet Mask	255.255.255.0

Appendix B- General Information

DESCRIPTION	SPECIFICATION
Interconnect Cable	CAT 5/5e/6 Solid UTP EIA/TIA 568B wiring w/ male RJ45 connectors
"RS232" Connector	9D female
"ETHERNET" Connector	RJ45 female
"AV IN" and "AV OUT" Connectors	RJ45 female
Operating temperature	+10°C to +40°C
Video quality adjustment	Automatic (up to 600 feet)
Replaceable fuse rating	2A 250V
Power requirements	110 or 220VAC, 50 or 60Hz, 1A

Appendix C- Distances and Resolutions for CAT5/CAT5e and CAT6 Cables

CABLE	DISTANCE (feet)	RESOLUTION
CAT5/CAT5e (UTP)	600	1024x768 at 60Hz
CAT5/CAT5e (UTP)	400	1280x1024 at 60Hz
CAT5/CAT5e (UTP)	300	1600x1200 at 60Hz
CAT5/CAT5e (UTP)	100	1920x1440 at 60Hz
CAT6 (UTP)	300	1024x768 at 60Hz
CAT6 (UTP)	200	1280x1024 at 60Hz
CAT6 (UTP)	100	1920x1440 at 60Hz

Appendix D- Product Dimensions

CONFIGURATION	SIZE (In.) WxDxH
SM-8X8-C5VA-LCD	19x12x1.75
SM-8X16-C5VA-LCD	19x12x1.75
SM-16X8-C5VA-LCD	19x12x1.75
SM-16X16-C5VA-LCD	19x12x3.5
SM-32X8-C5VA-LCD	19x12x3.5
SM-32X16-C5VA-LCD	19x12x3.5

Appendix E- Rack mounting Instructions

This NTI switch was designed to be directly mounted to a rack. It includes a mounting flange to make attachment easy. Install 4 cage nuts (supplied) to the rack in locations that line up with the holes (or slots) in the mounting flange on the NTI switch. Then secure the NTI switch to the rack using four #10-32 screws (supplied). Be sure to tighten all mounting screws securely.

Note: Do not block power supply vents in the NTI switch chassis (if provided). Be sure to enable adequate airflow in front of and behind the NTI switch.

Attach all cables securely to the switch and where necessary supply adequate means of strain relief for cables.

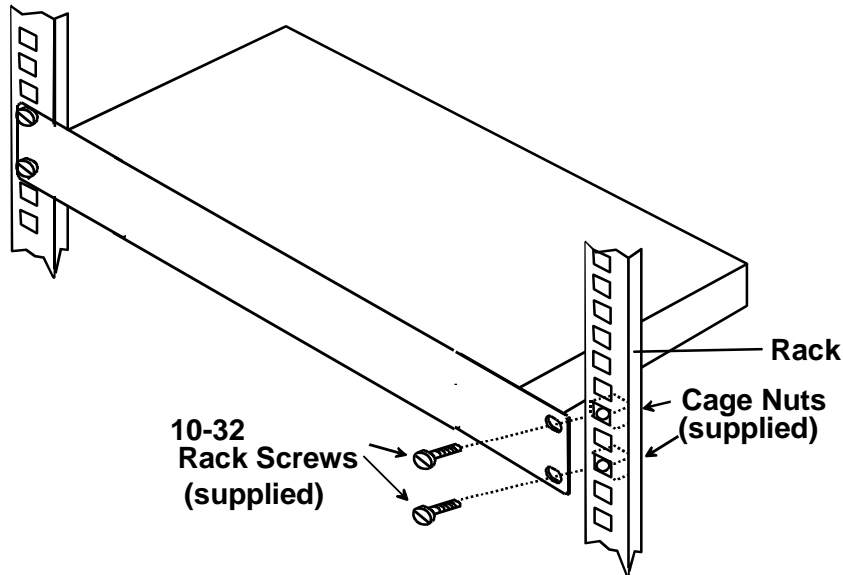

Figure 34- Mount Switch to a Rack

Grounding

These products have protective earth ground terminals and are built with full attention to consumer safety. There must be an un-interruptible safety earth ground between the main power source and the product's power cord or supplied power cord set. If ever the possibility exists for the grounding protection to have been reduced in any way, disconnect the power supply until the grounding connection has been fully restored.

Servicing

NTI products are not intended to be serviced in the field and contain no user-serviceable parts. In the event repair is needed, all servicing must be performed by factory trained and authorized service personnel. Only those items specifically identified in this manual (if any) may be adjusted by the user of this product and adjusted only as instructed in this manual.

INDEX

- 3.5mm jack, 6
- AC adapter, 7
- audio output, 13
- CAT5 cable, 30
- configuration menu, 11
- Device Discovery Tool**, 29
- direct connection, 9
- Ethernet cable, 9, 20
- Front panel, 10
- fuse, 2
- Green LED, 3, 7
- HyperTerminal, 14
- IP address, 20
- Keypad**, 10,11
- LCD**, 10
- Matrix Switcher's Control Program**, 15
- mounting in a rack, 33
- password-change, 27
- Password-Telnet**, 16
- powercord, 8
- RS232 interface**, 14
- Scanning Sequences**, 25
- serial cables, 30
- Setup pages**, 23
- Software control**, 17
- speakers, 4
- Switch page**, 21
- Telnet Interface**, 16
- Telnet Interface-Port 2005**, 17
- Troubleshooting**, 31
- Update Firmware**, 26
- username and password, 20
- web browsers, 1
- Web Interface**, 20
- Yellow LED, 7

WARRANTY INFORMATION

The warranty period on this product (parts and labor) is two (2) years from the date of purchase. Please contact Network Technologies Inc at **(800) 742-8324** (800-RGB-TECH) or **(330) 562-7070** or visit our website at <http://www.networktechinc.com> for information regarding repairs and/or returns. A return authorization number is required for all repairs/returns.